

# NELSON™ HEAT TRACING SYSTEMS

## ROOF & GUTTER DEICING SYSTEM FOR TYPE SLT AND CLT-JT HEATING CABLE & ACCESSORIES

## INSTALLATION INSTRUCTIONS

### DESCRIPTION

Nelson Heat Tracing Systems' **SLT and CLT-JT heater cables** provide a solution for ice dams that can build up and damage buildings and gutter systems. The cables' self-regulation feature provides additional benefits:

- **Lower Energy Consumption** - the cable reduces its power output as the ice and snow disappear.
- **Fail-Safe Temperature Limit** - the cable cannot overheat and melt or damage temperature sensitive roof coatings.

### COMPONENTS

**SLT-LPS Power Connection Kit**- includes moisture seals for both ends of the heater cable as well as a watertight entry seal into a junction box (not included in this kit). It is recommended that a NEMA 3R, 4 or 4X box be used and mounted under an eave or other protected area. Each kit will terminate one heater cable.

**SLT-ES Entry Seal Kit**- provides a watertight entry seal into a junction box (not included in this kit). It is recommended that a NEMA 3R, 4 or 4X box be used and mounted under an eave or other protected area. One entry per kit.

**SLT-C Universal Roof Mounting Clips**- are used for all types of installations. Clips come 25 to a box; order one box per eight feet of eave or one box for every 100 feet of cable installed on flat roofs.

**SLT-D- Downspout Hangars** are used to support the heater cable where it enters or exits a downspout. Hangars come in kits of 5; one is required for each downspout. If downspout is in the middle of a circuit, the cable is looped down to the bottom of drain and back up, clamping it into downspout hanger to prevent the cable from being pulled tight against drain/gutter edge. Each kit contains 5 hangars.

**SLT-S Splice Kit**- is used to splice two pieces of cable together. This could occur when additional cable is needed or a damaged spot must be cut out and repaired. Each kit contains 5 splices.

**SLT-E End Seal Kit**- provides a moisture seal at the end of each heater cable circuit. Each kit contains 5 seals.

**SLT-P Power End Seal Kit**- provides a moisture seal at the power connection end of the heating cable to prevent electrical arcing if condensation occurs in the connection box. Each kit contains 5 seals.

**AT-50 Aluminum Foil Tape**- may be used to secure the heater cable to the bottom of the gutter. Each roll of tape will accommodate 46M (150') of gutter. Gutter must be clean for foil tape to adhere properly. As an alternate, the cable may be laid loose in the bottom of the gutter without being secured with foil tape.

# NELSON™ HEAT TRACING SYSTEMS

## ROOF & GUTTER DEICING SYSTEM FOR TYPE SLT AND CLT-JT HEATING CABLE & ACCESSORIES

## INSTALLATION INSTRUCTIONS

### INSTALLATION INSTRUCTIONS

- ❶ Before installing heater cable, allow it to warm up to room temperature. Keep grommets and shrink tube warm until needed. (*keep inside of jacket pocket.*)
- ❷ Clear all gutters and downspouts of debris. (*protect hands with gloves.*)
- ❸ Remove any sharp edges that could damage the heater cable.
- ❹ Mount weatherproof junction box in a sheltered area.
- ❺ Start heater cable installation at the junction box, leaving a drip loop where the cable exits the junction box.
- ❻ Terminate heater cable per instructions and connect to power wiring with supplied wire nuts.
- ❼ It is recommended that the heater cable be megger tested between bus wires and ground braid after installation to verify cable integrity. Heater cable should have a minimum insulation resistance of 20 megohms when tested with at least a 500VDC megger, a 2500VDC megger is preferred.
- ❽ The circuit breaker can be used to turn the heater cable off and on. Optionally, an automatic snow or ice detector may be used to control the cable.

Two copies of a caution notice indicating the presence of electric deicing and snow melting equipment on the premises are included in the power connection/entry seal kits. One notice must be posted at the circuit breaker panel and the other notice posted next to the control device. Both notices must be clearly visible.

### WARNINGS:

- **Article 426 of the National Electric Code requires that all outdoor electric deicing and snow-melting equipment be provided with branch circuit ground-fault equipment protection.**
- **Moisture must be kept away from the live electrical parts of the cable or electrical faults will develop.**
- **If nuisance tripping of ground-fault breakers occurs due to condensation in the junction box, electrical connections should be moisture proofed by use of a coating or sealant.**
- **The cables ground braid must be connected to electrical ground for proper protection through circuit breakers. All electrical connections should be made by a licensed electrician.**
- **Do not twist bus wires together – this will result in a short circuit and damage the cable.**
- **Damaged heater cables must be repaired or replaced.**
- **Avoid laying ladders against the heater cable.**
- **Before energizing the circuit each season, make sure that the gutter system and downspouts are free of leaves and debris.**

# NELSON™ HEAT TRACING SYSTEMS

## ROOF & GUTTER DEICING SYSTEM

### FOR TYPE SLT AND CLT-JT HEATING CABLE & ACCESSORIES

## INSTALLATION INSTRUCTIONS

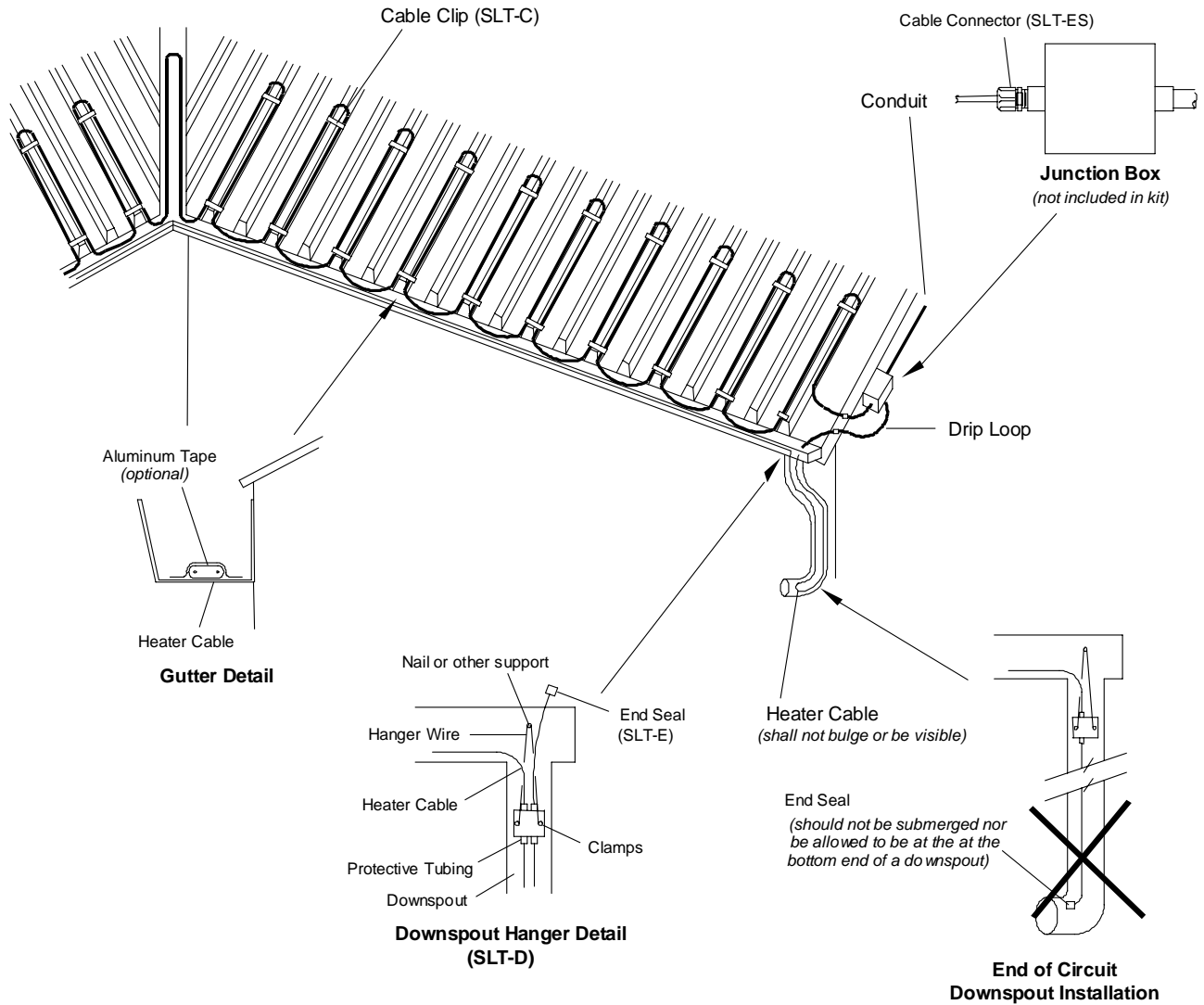

# NELSON™ HEAT TRACING SYSTEMS

## ROOF & GUTTER DEICING SYSTEM

### FOR TYPE SLT AND CLT-JT HEATING CABLE & ACCESSORIES

## INSTALLATION INSTRUCTIONS

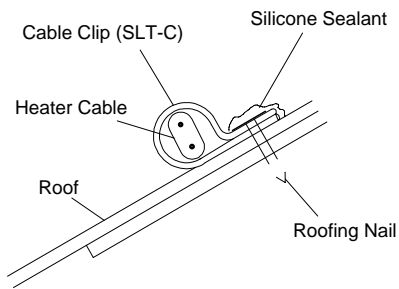

**Asphalt/Shake Shingle Roof** - Fasten with nail, coat nail head and upslope edge of clip with silicone sealant.

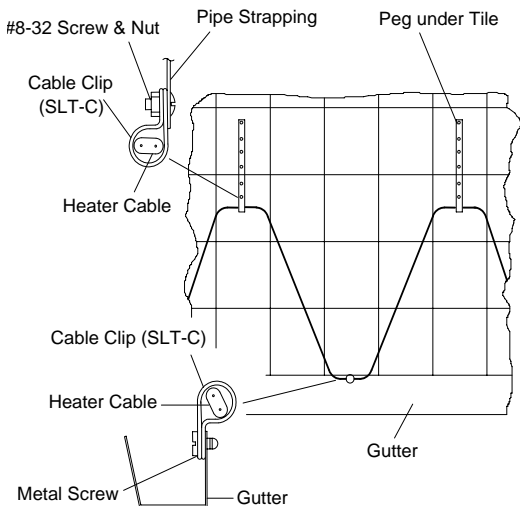
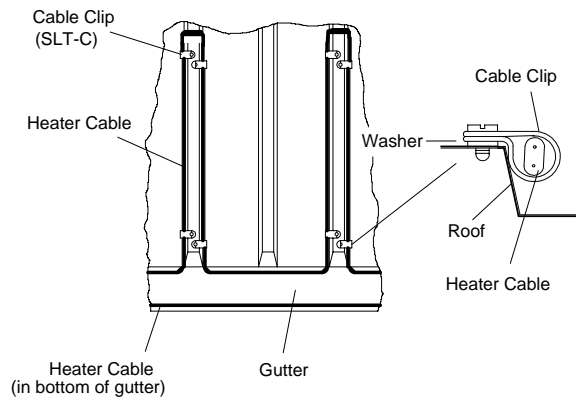

**Tile Roof** - Use perforated pipe strapping to attach the clips to the roof. For new construction, the strapping should be secured to the wooden substructure by means of pegging or nailing as the roof tiles are installed. For existing tile roofs, a bead of adhesive (not furnished) should run along the perforated strapping for a length of 76mm (3") prior to slipping the strapping up under the tile. **Do not use an excessive amount so as to leave a visible blob of adhesive on the outer edge of the tile.** The adhesive bead should be large enough to deform and smear along the underneath surface of the tile. Allow the adhesive cure to full bonding strength before attempting to install the cable and clips.

**Metal Roof** - Fasten with sheet metal screw using neoprene sealing washer. If washers are not available, coat screw and upslope edge of clip with silicone sealant. Exact cable spacing may vary depending on the rib design of the roof. Typically trace every other rib.

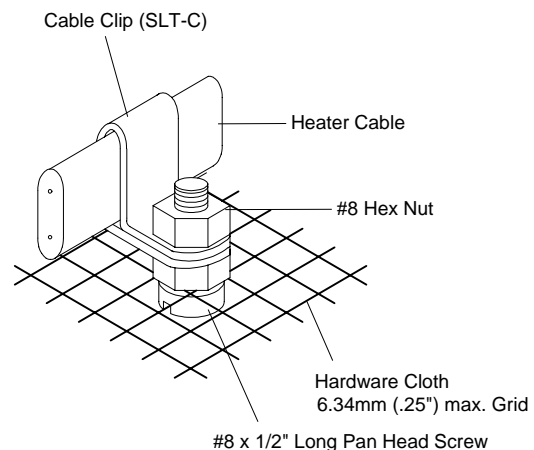

**Flat Roof** - Adhesive (not furnished) should be used to bond clips studs to the flat surface. The roof surface should be clean at the bonding locations. **Do not penetrate flat roofs with screws or nails as leaks may develop.** Allow the adhesive to cure to full bonding strength before attempting to install the cable and clips.

Nelson Heat Tracing Systems products are supplied with a limited warranty. Complete Terms and Conditions may be found on Nelson's website at [www.nelsonheaters.com](http://www.nelsonheaters.com).